

WAGNER

0 1 2 3 4 5 6 7 8 9
 0 1 2 3 4 5 6 7 8 9
 € 1 2 3 4 5 6 7 8 9
 0 1 2 3 4 5 6 7 8 9

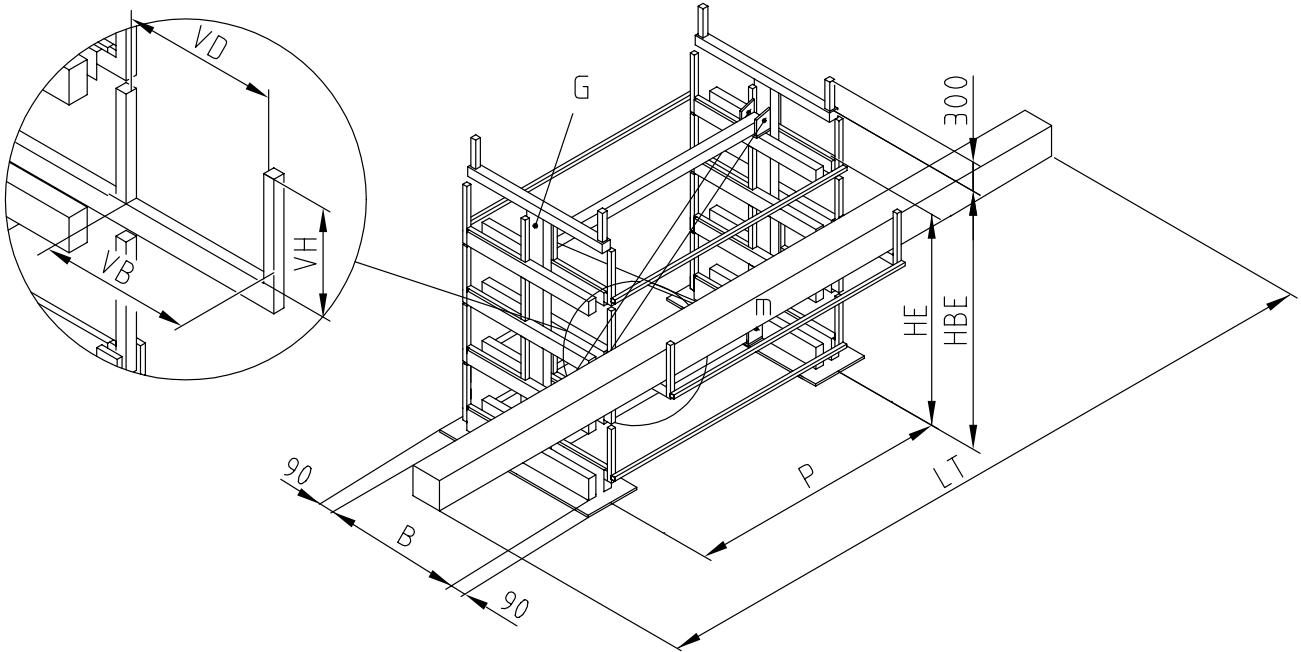

VD	VB	B	m
			2G
720	750	1700	1000
920	950	2100	750
1120	1150	2500	500

VH	ETAGES ETAGEN STORIES ETAGES	HE	HBE
	200	2x3+1	938
2x4+1		1297	1588
2x5+1		1656	1947
2x6+1		2015	2306
300	2x3+1	1138	1529
	2x4+1	1597	1988
	2x5+1	2056	2447
400	2x3+1	1338	1829
	2x4+1	1897	2388
500	2x3+1	1538	2129
	2x4+1	2197	2788

ML	G GRIDS	P	LT
1000	2	700	1000
2000	2	1140	2000
3000	2	1640	3000
4000	2	2200	4000
5000	2	2760	5000
6000	2	3350	6000

TYPE AANDUIDING, TYPBEZEICHNUNG, TYPE INDICATION, TYPE DESCRIPTION :

MULTI-4E-2G-92X20 ML=6000mm

MATERIALLENGTE, MATERIALLENGE,
 MATERIALLENGTH, LONGUEUR DU MATERIEL, ML.
 VAKAFMETING, FACHABMESSUNG, COMPARTMENT MEASUREMENTS,
 DIMENSIONS COMPARTIMENTS, VDxVH.
 2 DRAAGELEMENTEN, TRAGELEMENTE, SUPPORTS, MONTANTS.
 2 X 4 ETAGES, ETAGEN, STORIES, ETAGES
 + 1 BOVENETAGE, OBERE ETAGE, TOP STORIE, ETAGE SUPERIEUR.
 UITVOERING, AUSFUHRUNG, SYSTEM, TYPE.

WAGNER

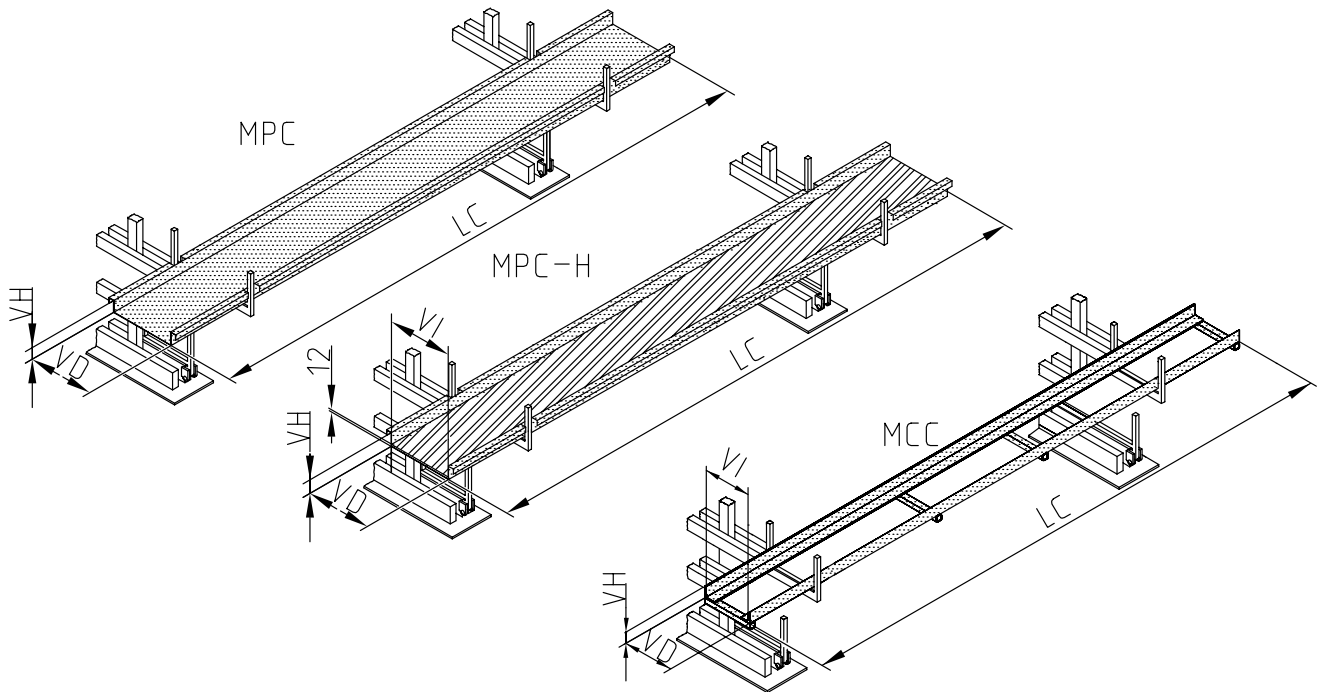

TYPE TYP TYPE TYPE	VH	ML	LC	VD	VI
MPC	100	3000	2900	1120	1100
MPC-H				920	900
MCC	80	6000	5900	720	700

TYPE AANDUIDING, TYPBEZEICHNUNG, TYPE INDICATION, TYPE DESCRIPTION :

MCC-290-72x8

VAKAFMETING, FACHABMESSUNG, COMPARTMENT MEASUREMENTS,
DIMENSIONS COMPARTIMENTS, VDxVH.

CASSETTELENGTE, KASSETTELENGE,
CASSETTELENGTH, LONGUEUR DES CASIER, LC.

- MPC - PLAATSTALEN CASSETTE, BLECHWANNEN CASSETTE, PLATESTEEL CASSETTE, CASIER EN TOLE D'ACIER.
- H - BEKLEDING HOUT, VERKLEIDUNG HOLZ, WITH WOOD, AVEC BOIS
- MCC - PROFIEL CASSETTE, PROFIEL KASSETTE, PROFIL CASSETTE, CASIERS EN PROFILES

m=kg $\overbrace{\text{mm}}$

Alterations reserved

01D50402