

WAGNER

© Wagner
 02 46 46 46 46
 € 11 11 11 11 11
 VB [, a) \ a D , æ } ^ ! E o c ! } E ^

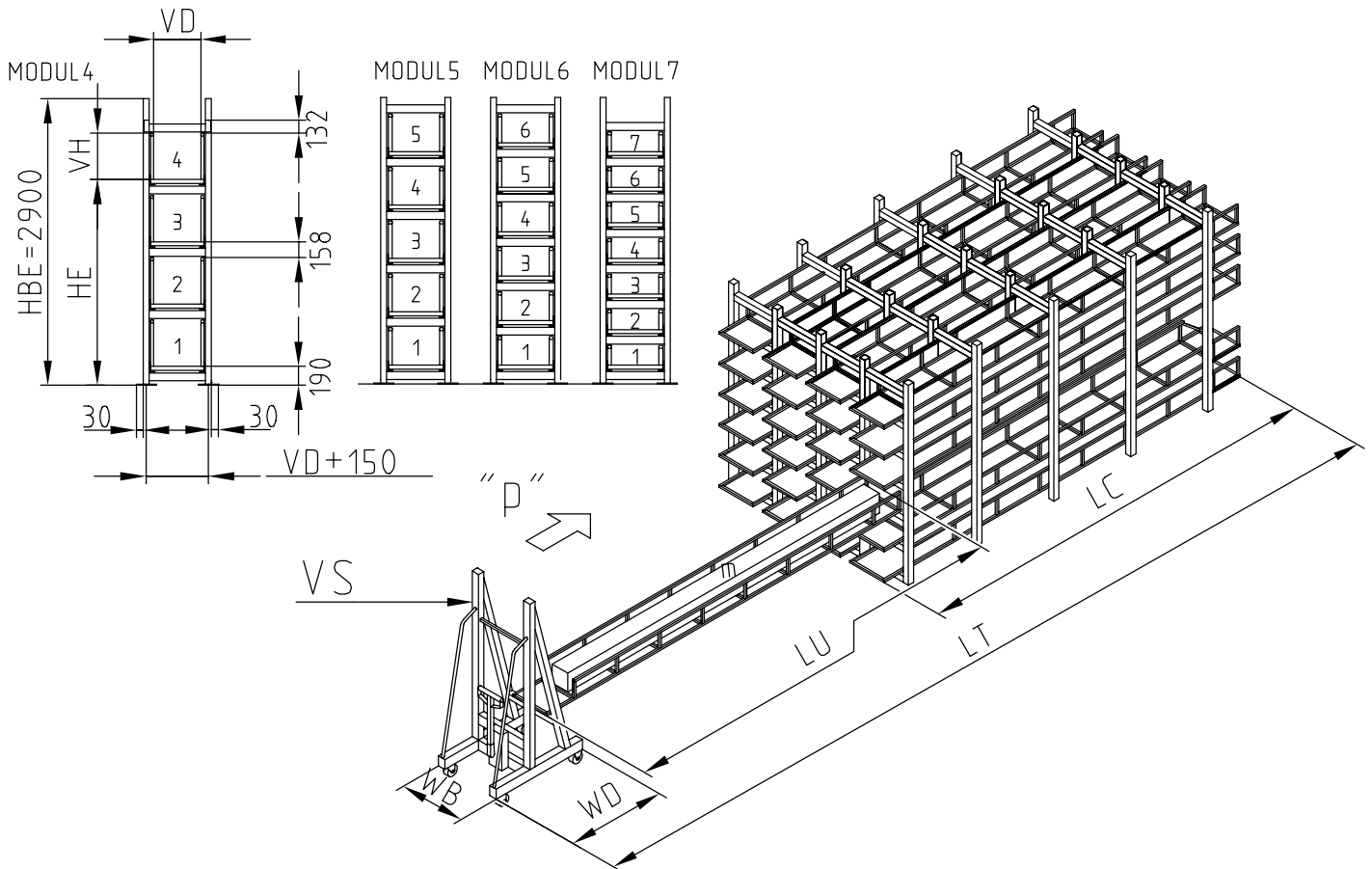

	m	VH	HE
MODUL 4	1500	470	2080
MODUL 5	1500	380	2350
MODUL 6	1500	290	2440
MODUL 7	1500	200	2350

VD	WB	WD
380	1400	1360
580	1400	1360
780	1400	1360
980	1400	1360

ML	LC	LU	LT
3000	3200	3000	7200
4500	4700	4500	10200
6000	6200	6000	13200

TYPE AANDUIDING, TYPBEZEICHNUNG, TYPE INDICATION, TYPE DESCRIPTION :

MODUL6-4V/6C-38X29-ML=6000mm

MATERIAALLENGTE, MATERIAALLANGE, MATERIALLENGTH, LONGUEUR DU MATERIEL, ML.
 VAKAFMETING, FACHABMESSUNG, COMPARTMENT MEASUREMENTS, DIMENSIONS COMPARTIMENTS, VDxVH.
 AANTAL CASSETTEN, ANZAHL CASSETTEN, NUMBER OF CASSETTES, NOMBRE DE CASSETTES.
 AANTAL VELDEN, ANZAHL FELDEN, NUMBER OF FIELDS, NOMBRE DE COLONNES.

m=kg mm

Alterations reserved

23D50101

WAGNER

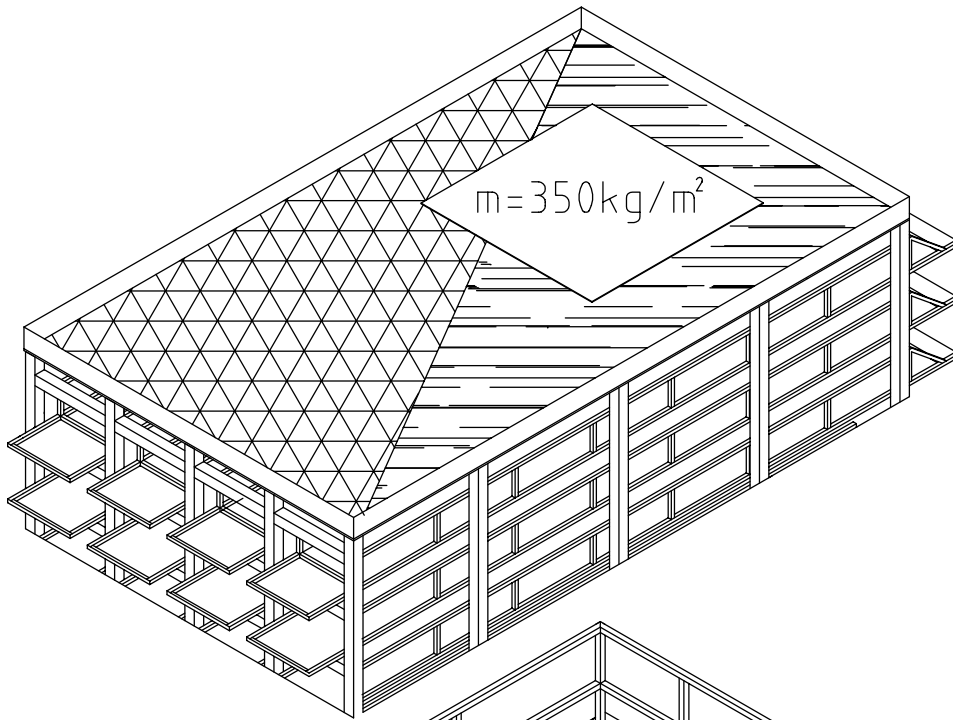

	M
MODUL-TOP	350

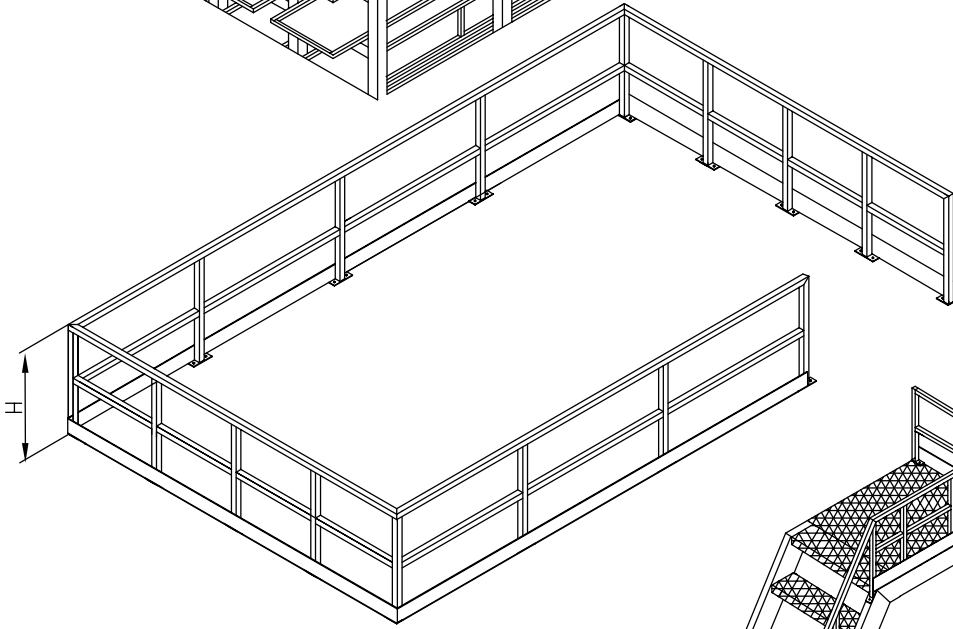

	H
MODUL-R	900

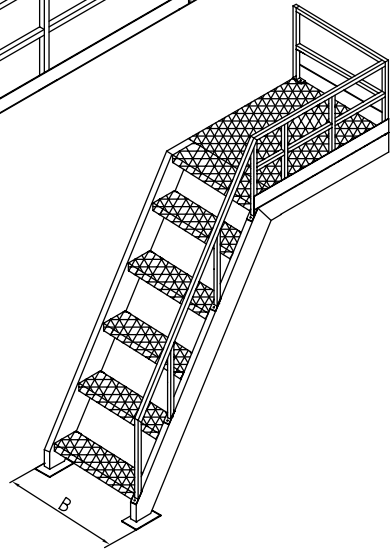

	B
MODUL-S	900

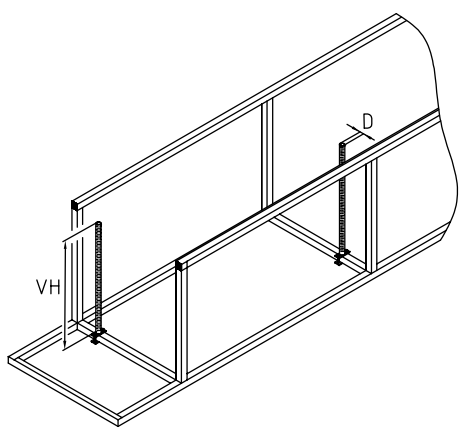

	D	VH
VP-20	27	200
VP-29	27	290
VP-38	27	380
VP-47	27	470

m=kg $\left\langle \begin{array}{c} \text{mm} \\ \leftarrow \rightarrow \end{array} \right\rangle$
 Alterations reserved

23D50201